

Catabourne 12" (nominal) cat

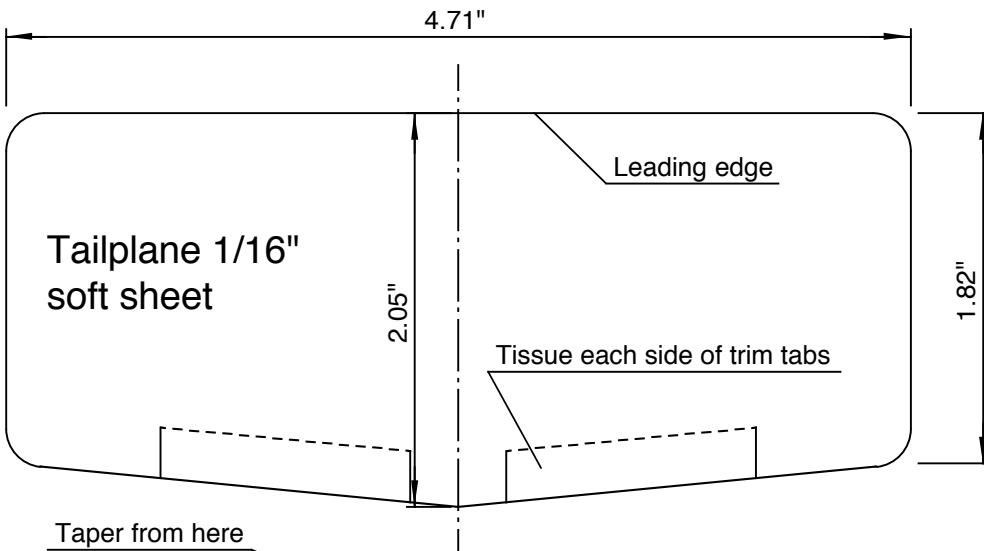

- Trimming notes:
- (1) CG 50% of wing c
 - (2) Bend fin tab a little
 - (3) Hand glide to obt
 - (4) make sure there is
 - (5) Catapult model wi
- Fault
- Model goes straight u
- Model loops
- Model turns too tight l

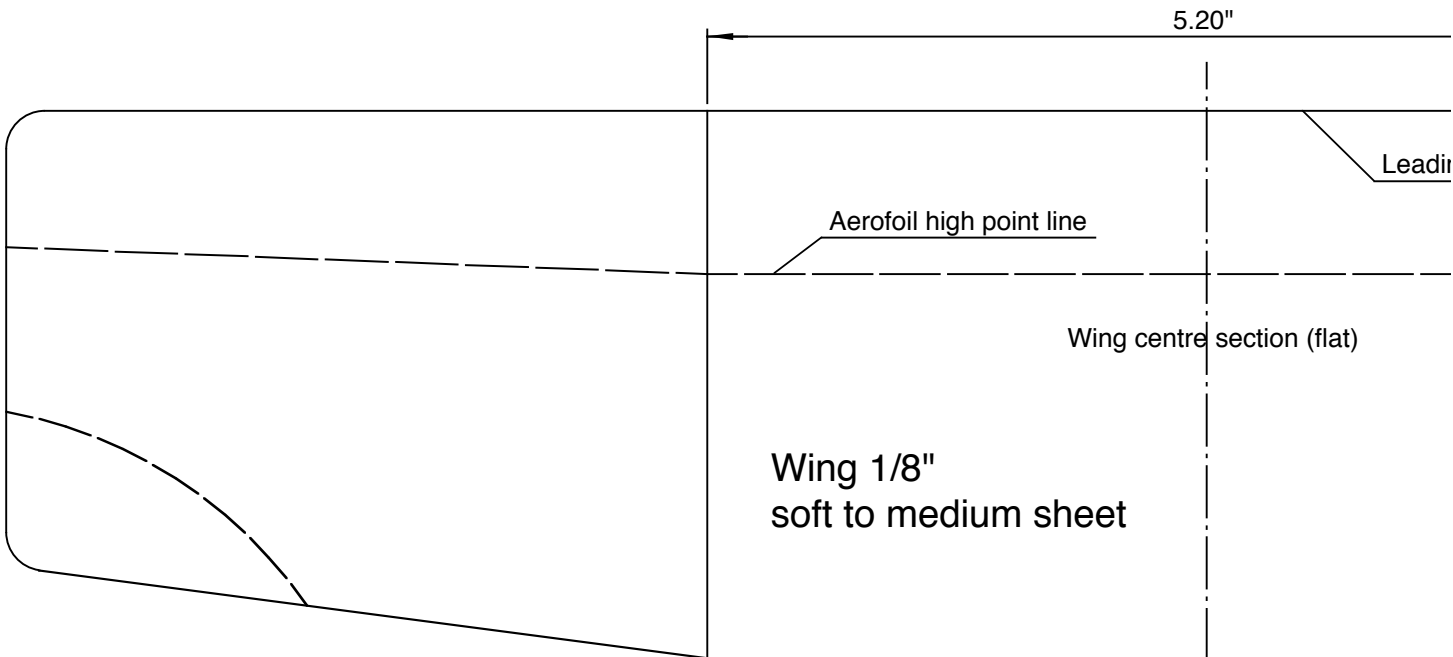
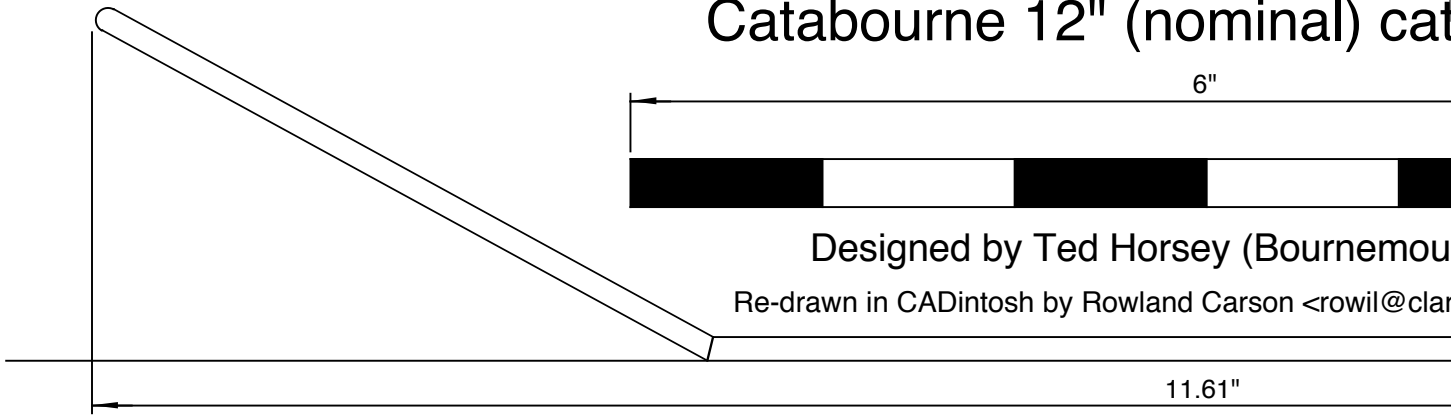
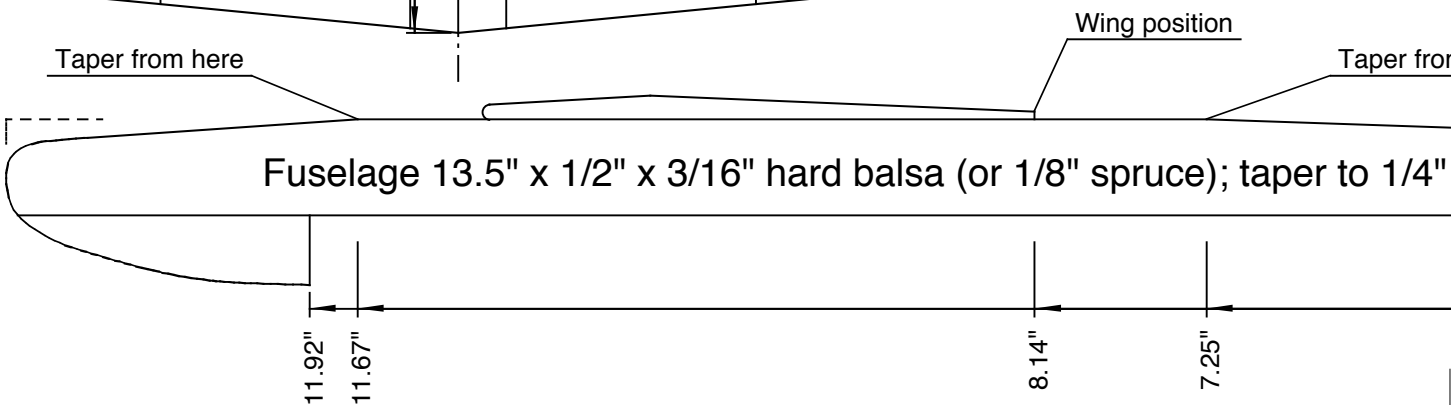

Capult glider

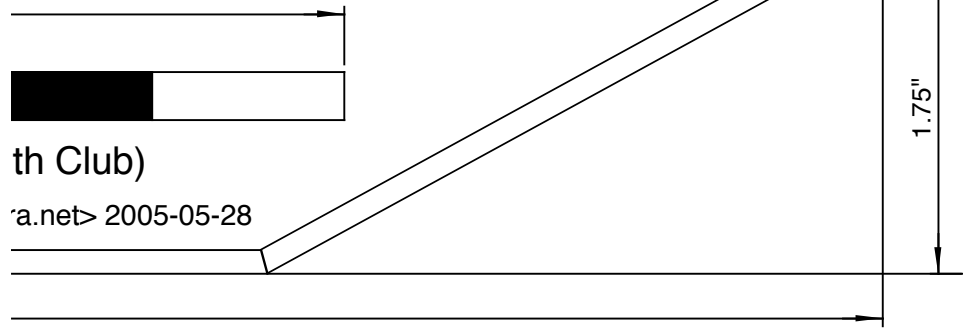

th Club)

ra.net> 2005-05-28

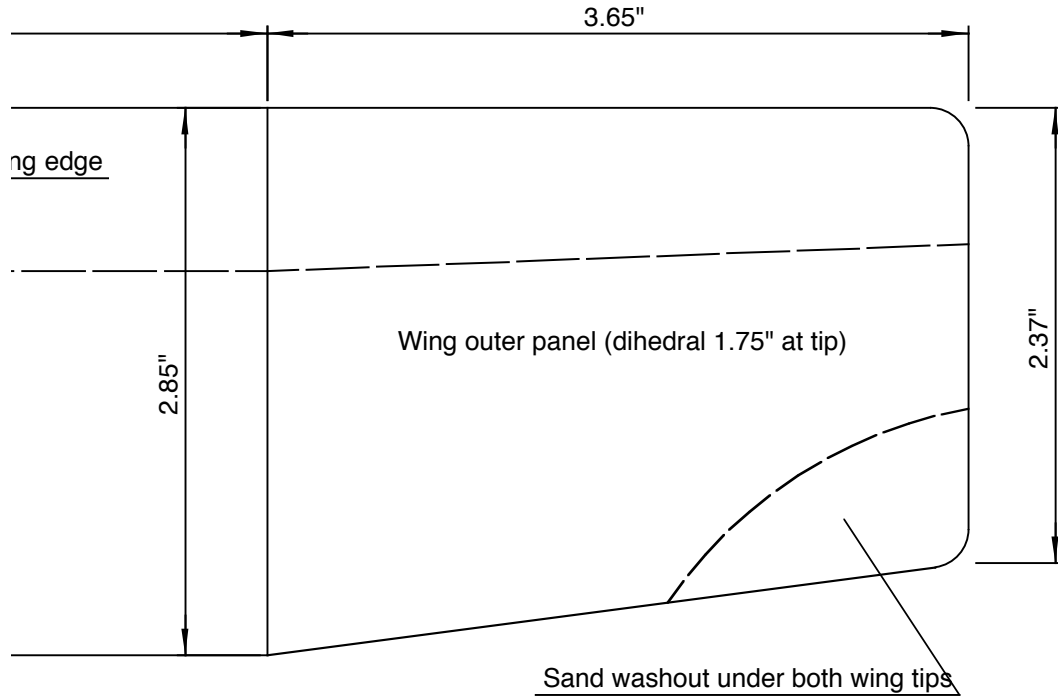

chord
 e left
 in a very slight left turn
 s no trace of stall
 th slight R bank and 45° angle

Launch with 6" loop of 1/4" FAI rubber attached to 6" x 1/2" dowel

ip and down Answer
 Bend up TE of tailplane
 R or L Bend down TE of tailplane
 Less L or R rudder

n here

at rear, to 3/8" at front

